

LM Guide Type JR – Structural-Rail, Four-Way Equal-Load Type

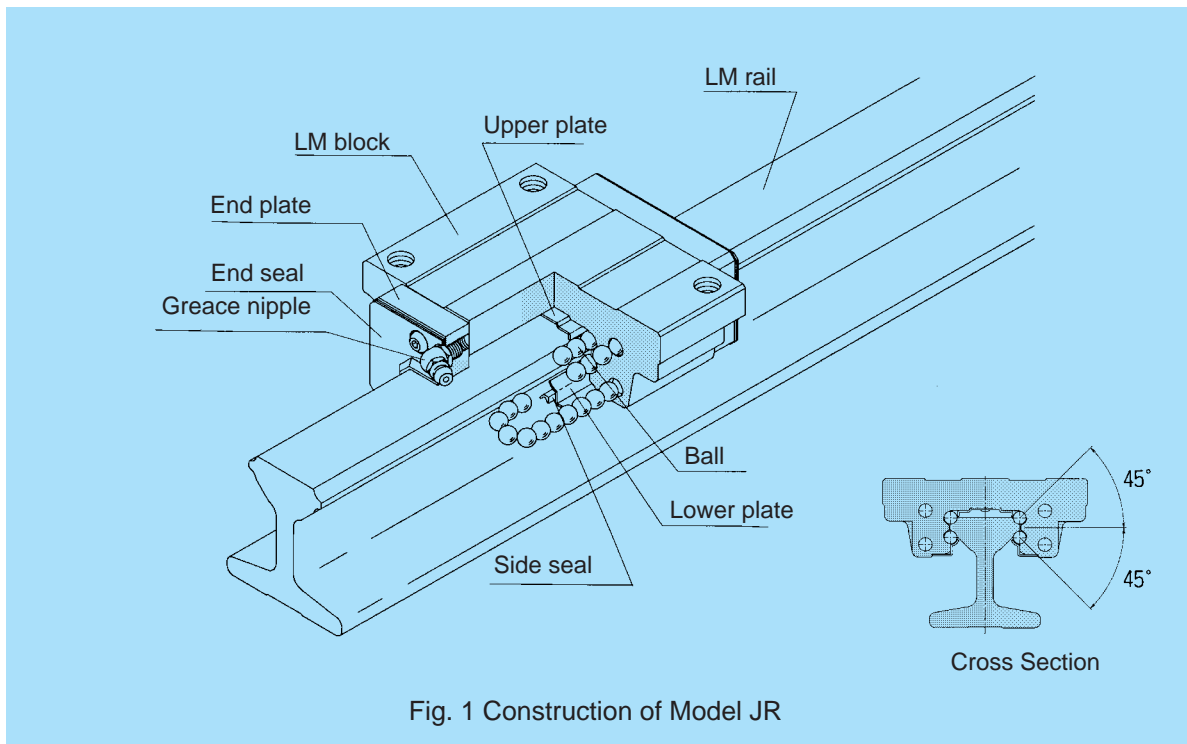

Construction and Features

Balls roll in four rows of precision-ground raceway on an LM rail and an LM block. The end plate attached to the LM block causes the trains of balls to circulate. As the balls are held in place by the retainer plate, they do not fall off if the LM block is removed from the rail.

JR employs an LM block of type HSR, which has proven high performance and reliability. The LM rails for type JR were designed to be highly flexible, so as to give them high bending rigidity and excellent self-adjusting capability.

While in conventional LM Guides the LM rails must be bolted to the mounting base, in type JR the base and LM rails are formed into one unit. The rail top structure is the same as that of type HSR, and the rail bottom structure, with a hardness of $H_R C25$ or lower, can be machined and welded.

If the rail is welded, use of the welding rod stipulated in JIS D5816 (one of the applicable products: LB-52, Kobe Steel) is recommended

Four-way equal load

The raceways are arranged at 45° in relation to one another so that each train of balls bears an equal load rating in all four directions: radial, reverse-radial, and the two lateral directions. This type can therefore be used in any installation direction.

Coarse installation acceptable

LM rails of this type have a thin central part. Should two axes lack accurate parallelism, this enables the rail to absorb the error, due to inward or outward deflection.

Geometrical moment of the inertia of LM-rail cross sections

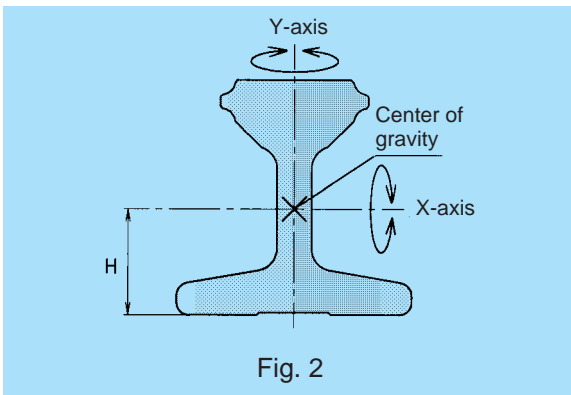

Fig. 2

Cross-sectional shape to provide high bending rigidity

As the LM-rail cross section of type JR is formed into a shape that ensures high bending rigidity, LM Guide type JR can be used as a structural member. Even if a rail is only partly fastened or must support a load on one side only, distortion can be minimized.

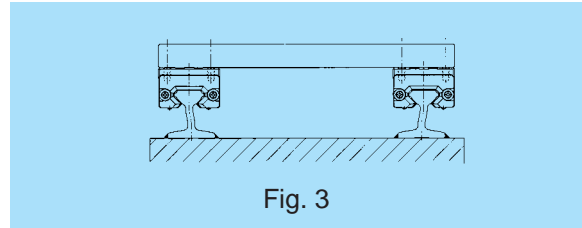
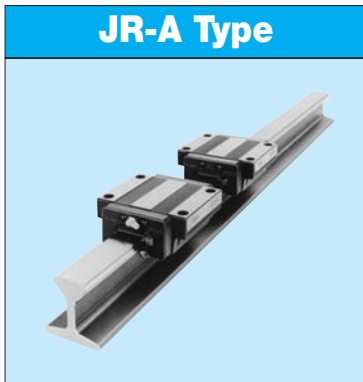

Fig. 3

	Geometrical moment of the inertia of a cross section I [x 10 ⁵ mm ⁴]		Cross-section factor Z [x 10 ⁴ mm ³]		Height of the center of gravity H [mm]
	Near the X-axis	Near the Y-axis	Near the X-axis	Near the Y-axis	
JR 25	1.90	0.51	0.69	0.21	19.5
JR 35	4.26	1.32	1.43	0.49	24.3
JR 45	12.1	3.66	3.31	1.04	33.1
JR 55	27.6	6.54	5.89	1.40	43.3

Types and Features



The flange of the LM block is provided with tapped holes to enable simple assembly, making it suitable for use in build-up systems.

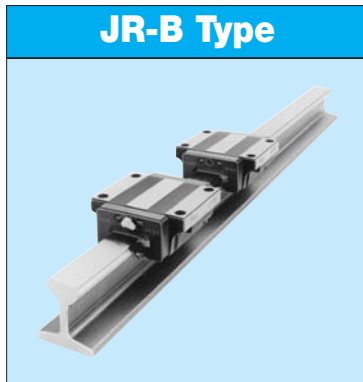

The LM blocks can be attached to a table from below. For use with a table in which a through hole cannot be drilled.

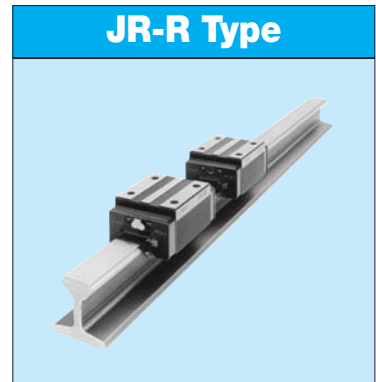

The narrowed flange of the LM block is provided with tapped holes, making it convenient for use in build-up systems.

Load Rating and Permissible Moment in Various Directions

Load rating

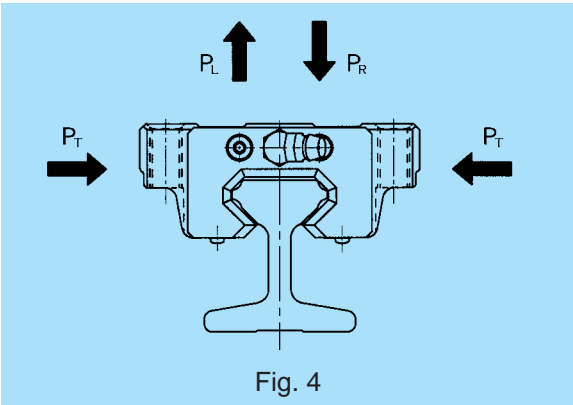

Type JR can bear loads applied in all four directions: radial, reverse-radial, and the two lateral directions.

The basic load ratings in all four directions (radial, reverse-radial and the two lateral directions) are equivalent to one another. The values are given in the corresponding dimension tables.

Equivalent load

The equivalent load for type JR when loads applied in all four directions are applied to its LM block simultaneously can be obtained using the following equation:

$$P_E = P_R (P_L) + P_T \quad (N)$$

where

- P_E : equivalent load (N)
 - In the radial direction
 - In the reverse-radial direction
 - In the lateral direction
- P_R : radial load (N)
- P_L : reverse-radial load (N)
- P_T : lateral load (N)

Permissible moment

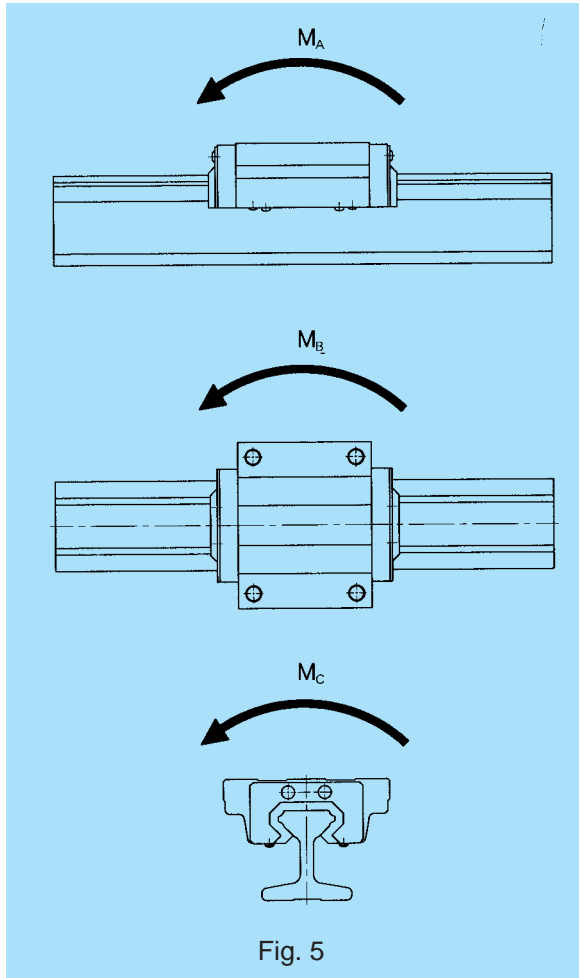

In type JR, a single LM block can bear moments in all directions. Table 1 gives the permissible moments in directions M_A , M_B , and M_C for a single LM block.

Table 1 Type JR Static Permissible Moment

Unit: kNm

Model No.	M_A	M_B	M_C
JR 25	0.27	0.27	0.4
JR 35	0.64	0.64	1.0
JR 45	1.3	1.3	2.1
JR 55	2.2	2.2	3.6

Accuracy Standards

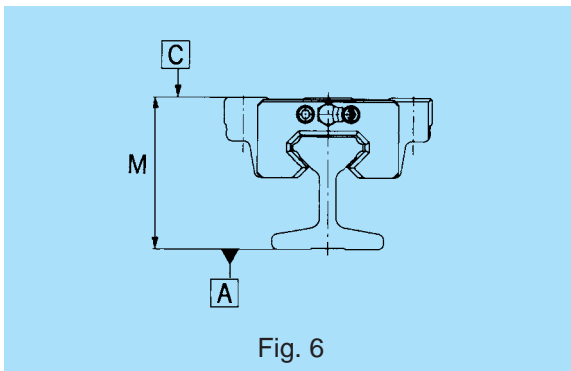

Fig. 6

The accuracy of type JR is given in Table 2 for each model number.

Table 2 Type JR Accuracy Standard

Unit: mm

Model No.	Accuracy standard	Normal
	Item	No symbol
JR 25 JR 35	Tolerance for the height M difference among LM blocks	0.05
	Running Parallelism of surface C with surface A	C (as per Fig. 7)
JR 45 JR 55	Tolerance for the height M difference among LM blocks	0.06
	Running Parallelism of surface C with surface A	C (as per Fig. 7)

A-IV

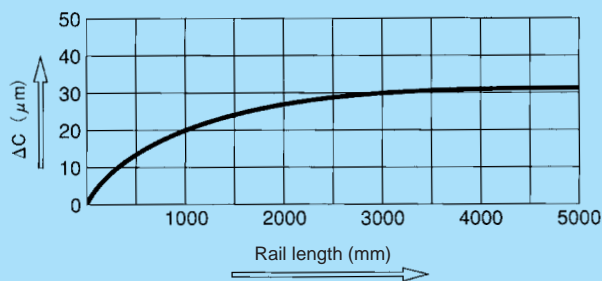

Fig. 7 Relationship Between LM-Rail Length and Running Parallelism

Radial clearance

Table 3 presents the radial clearances of types JR.

Table 3 Type JR Radial Clearances

Unit: μm

Model No.	Clearance symbol	Normal
	No symbol	
JR 25		- 6 ~ + 3
JR 35		- 8 ~ + 4
JR 45		- 10 ~ + 5
JR 55		- 12 ~ + 5

Radial clearance

JR 35 R 2 UU + 1200L

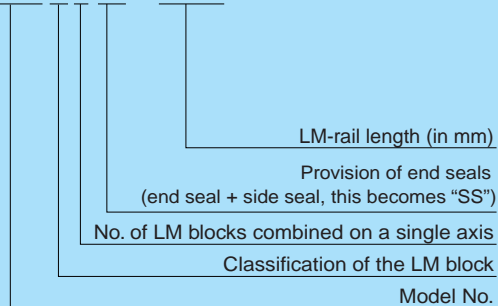

Note: This coding is based on the assumption of one set of code for a one-axis unit.
(A configuration of two axes installed in parallel is given at least two sets of code.)

Contamination Protection

From our wide range of products for type JR, you can select the one best suited for your situation. (For details on seals, see “Contamination Protection” for type HSR on page A-249.)

Side seal

Prevents contaminants from entering an LM block from below.

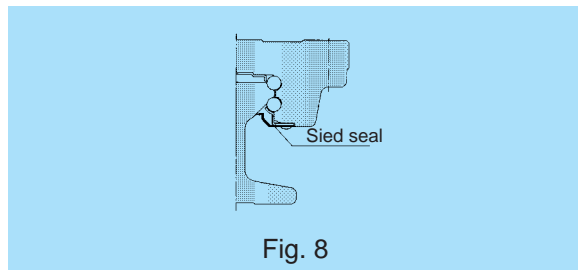

Contamination-protection-accessory symbol

Where a contamination-protection accessory is required, specify so using the symbols shown below.

Some models do not accept contamination-protection accessories. Confirm which parts are applicable by referring to Table 4.

Attaching a contamination-protection accessory to an LM block changes the block overall length. Add to dimension L the increment specified in the corresponding dimension table.

Table 4 Type JR LM Block Overall Length with a Contamination-protection Accessory Attached

Unit: mm

Model No.	No symbol	UU	SS	DD	ZZ	KK
JR 25	O	76.6	O	83.5	O	97.5
JR 35	O	102.4	O	114	O	134
JR 45	O	132	O	145	O	164.8
JR 55	O	156	O	165	O	180.8

Note: O = Applicable

Δ = Applicable, but a grease nipple cannot be attached.

Scraper

Removes spatters and similar large foreign matter.

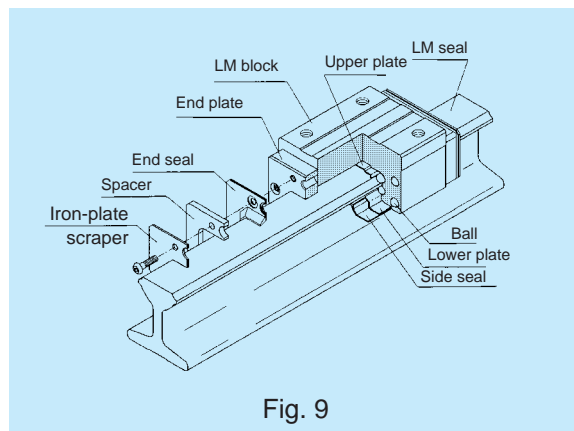

Seal resistance value

For the maximum value of seal resistance of seals type JR...UU per LM block in which grease is applied, see Table 5.

Table 5 Maximum Resistance Value of seals to Type JR

Unit: N

Model. No.	Seal resistance value
JR 25	3.9
JR 35	11.8
JR 45	19.6
JR 55	19.6

Bellows for Type JR

The bellows for type JR is identical to that for HSR. See the description of the bellows designed for type HSR on pages A-252 through 254.

However, for a bellows to be used for connected LM rails, contact us.

Precautions on Use

Mounting-Surface Height and Corner Profile

Normally, mounting surfaces for LM blocks and rails have lateral reference surfaces to aid in positioning rails and blocks with a high degree of accuracy.

For the reference-surface shoulder height, see Table 6.

Furthermore, provide enough space to the corner profile of a mounting surface so that the corner does not interfere with chamfers made on the LM blocks or rails, or provide the corner with a radius smaller than corner radius r specified in Table 6.

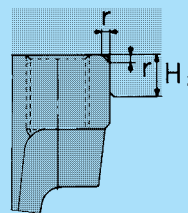

Fig. 10

Table 6 Mounting-Surface Shoulder Height and Corner Radius

Unit: mm

Model No.	Corner radius r (Max.)	LM rail shoulder height H_2
JR 25	1.0	5
JR 35	1.0	6
JR 45	1.0	8
JR 55	1.5	10

LM-Rail mounting procedures

In the parallel two-axis configuration shown, first fasten a rail to the base, and then attach a dial gauge to the LM-block top surface. Next, while maintaining contact between the gauge probe and the side and top surfaces of the other rail, adjust the parallelism and level, and fasten the rail in place.

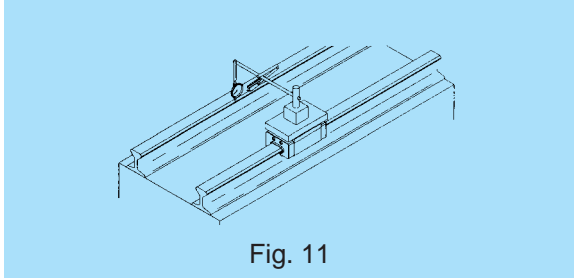

Fig. 11

Procedures for connecting LM rails

We offer the fixtures specified below for connecting LM rails.

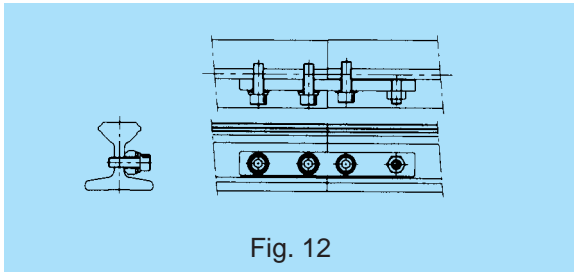

Fig. 12

Procedures for mounting LM rails by welding

When welding an LM rail to the base, fixing the welding point using a squill vice is recommended. The recommended welding conditions are specified below. (Be sure to protect the rail raceways from welding spatter.)

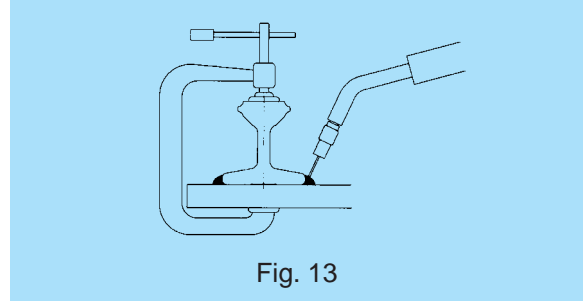

Fig. 13

* Welding conditions

- Preheating temperature: 200 °C
- Post-heating temperature: 350 °C

Note: Temperatures over 750 °C may re-harden material steel.

- For shielded metal arc welding: Covered electrode = LB-52 (Kobe Steel)
- For CO₂-gas-shielded arc welding:
Wire = YGW12; current: 200 A

LM-rail standard and maximum lengths

Model No.	Standard rail length			Maximum rail length
JR 25	1000	1500	2000	2000
JR 35				
JR 45	1000	2000	4000	4000
JR 55				

LM-Rail Clamping Block JB

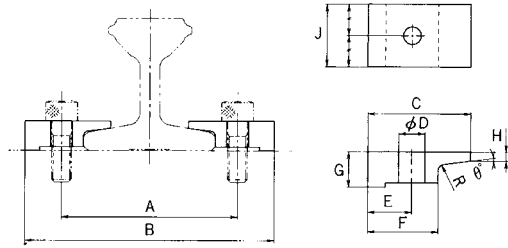

Unit: mm

Model No.	Center-to-center distance		Clamp dimensions									Mounting bolt
	A	B	C	ØD	E	F	G	H	R	J	θ°	
JB 25	57	78	25	7	10.5	15	10	3.8	R2	25	10	M 6
JB 35	72	102	35	9	15	24	12	3.1	R2	32	8	M 8
JB 45	90	130	45	11	20	30	16	5.4	R2	40	8	M10
JB 55	115	155	50	14	20	30	17	8.2	R2	50	10	M12

LM-Rail Clamping Iron Plate JT

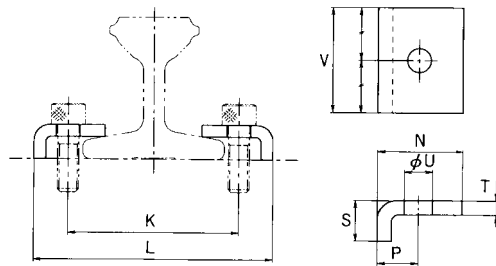

Unit: mm

Model No.	Center-to-center distance		Clamp dimensions						Mounting bolt
	K	L	N	P	S	T	ØU	V	
JT 25	57	79	25	11	10	4	7	25	M 6
JT 35	65	91	27	13	13	4.5	9	40	M 8
JT 45	84	114	33	15	16	6	11	50	M10
JT 55	110	148	50	19	15	6	14	50	M12

JR-A/B/R Type

Standard Type



JR-A Type



JR-B Type



JR-R Type

Model No.	Classification of the LM block	External dimensions			LM block dimensions								
		Height M	Width W	Length L	B	C	S × l	∅H	L ₁	T	T ₁	K	
JR 25	A	61	70	83.5	57	45	M8 × 16	-	59.5	10	16	30.5	
	B	61	70		57	45	-	7		10	16	30.5	
	R	65	48		35	35	M6 × 8	-		8	-	34.5	
JR 35	A	73	100	114	82	62	M10 × 21	-	80.4	13	21	40	
	B	73	100		82	62	-	9		13	21	40	
	R	80	70		50	50	M8 × 12	-		12	-	47.4	
JR 45	A	92	120	145	100	80	M12 × 15	-	98	14	25	50	
	B	92	120		100	80	-	11		15	25	50	
	R	102	86		60	60	M10 × 17	-		16	-	59.4	
JR 55	A	114	140	165	116	95	M14 × 17	-	118	15	29	57	
	B	114	140		116	95	-	14		17	29	57	
	R	124	100		75	75	M12 × 18	-		18	-	67	

Notes:

- For permissible static moments M_A , M_B , and M_C , see page A-280.
- For model-number coding, see page A-281.
- For the LM-rail standard length, see “LM-Rail Standard and Maximum Lengths” on page A-284.

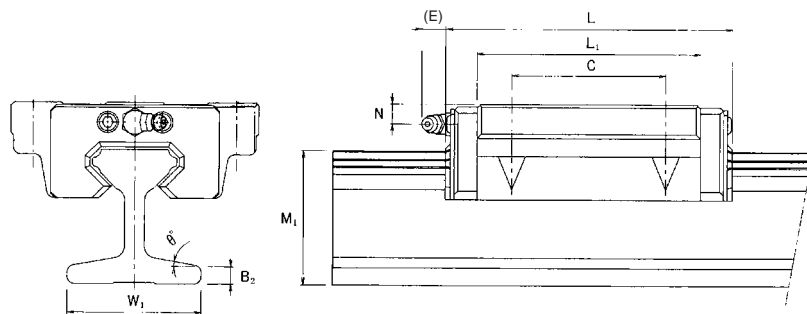

Unit : mm

N	E	Grease nipple	LM-rail dimensions					Basic load rating		Mass	
			Width W ₁	W ₂	B ₂	θ°	Height M ₁	C kN	C ₀ kN	LM block kg	LM rail kg/m
6	12	B-M6F	48	5	4	12	47	19.9	34.4	0.59	4.2
6										0.59	
10										0.54	
8	12	B-M6F	54	8	7	10	54	37.3	61.1	1.6	8.6
8										1.6	
15										1.5	
10	16	B-PT1/8	70	10	8	10	70	60	95.6	2.8	15.2
10										2.8	
20										2.6	
11	16	B-PT1/8	93	11.6	4.8	12	90	88.5	137	4.5	18.3
11										4.5	
21										4.3	

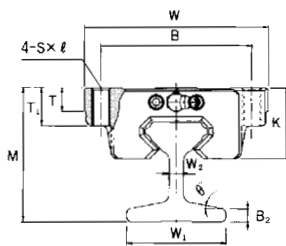

JR-A Type

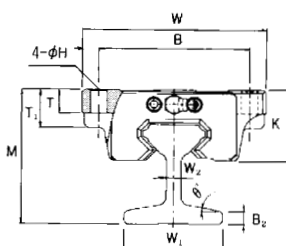

JR-B Type

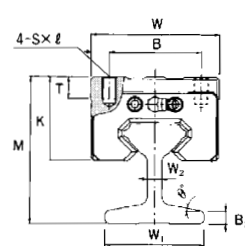

JR-R Type