



# Straight-Curved Guide HMG

## HSR TYPE MULTIMOTION GUIDE

“LM Guide” + “R Guide” =  
“Straight-Curved Guide”

Allows simplification of mechanisms at  
assembly line, transport line and inspection line

# HMG



## Structure of the Straight-Curved Guide HMG

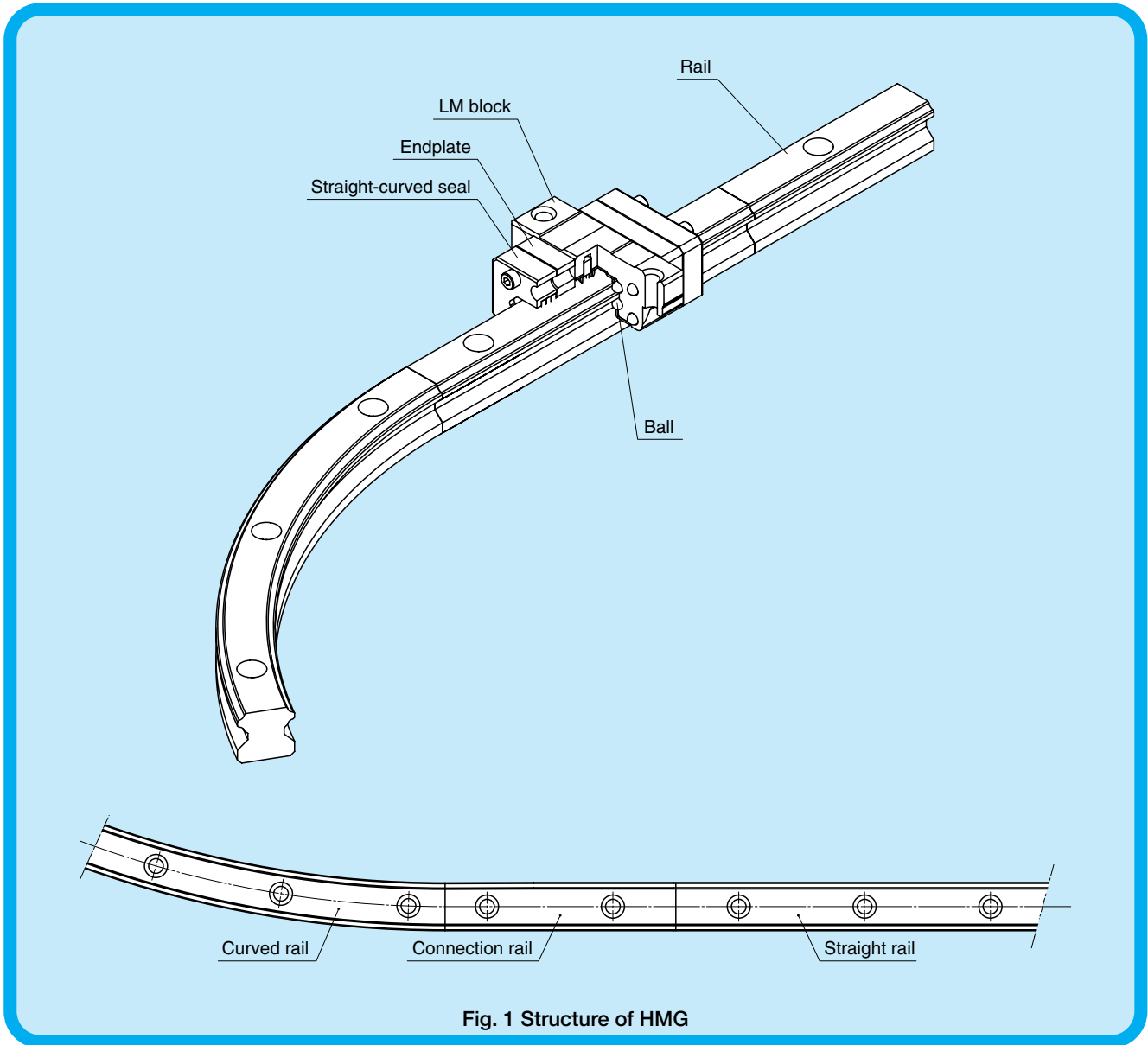

HMG uses a special structure that allows the same type of LM blocks to continuously move on straight and curved rails by combining the technologies of the LM Guide and the R Guide. It is an innovative linear motion guide as a guide component for conveyance systems.

## Features of HMG

The Straight-Curved Guide HMG is a new straight-curved guide that allows the same type of LM blocks to continuously move on straight and curved rails by combining the technologies of the LM Guide HSR and the R Guide HCR. It achieves drastic cost reduction through improvement of work efficiency at the assembly and conveyance lines and the inspection equipment and simplification of the structure by eliminating a lift and a table.

### Free designing

It allows free combinations of straight and curved shapes.

Since LM blocks can smoothly transit between the straight and curved sections, various combinations of straight and curved rails can be joined into various shapes such as O, U, L and S shapes. In addition, HMG allows a large table to be mounted and a heavy object to be carried through combinations of multiple blocks on a single shaft or 2 or more LM rails. Thus, it provides great freedom of designing.

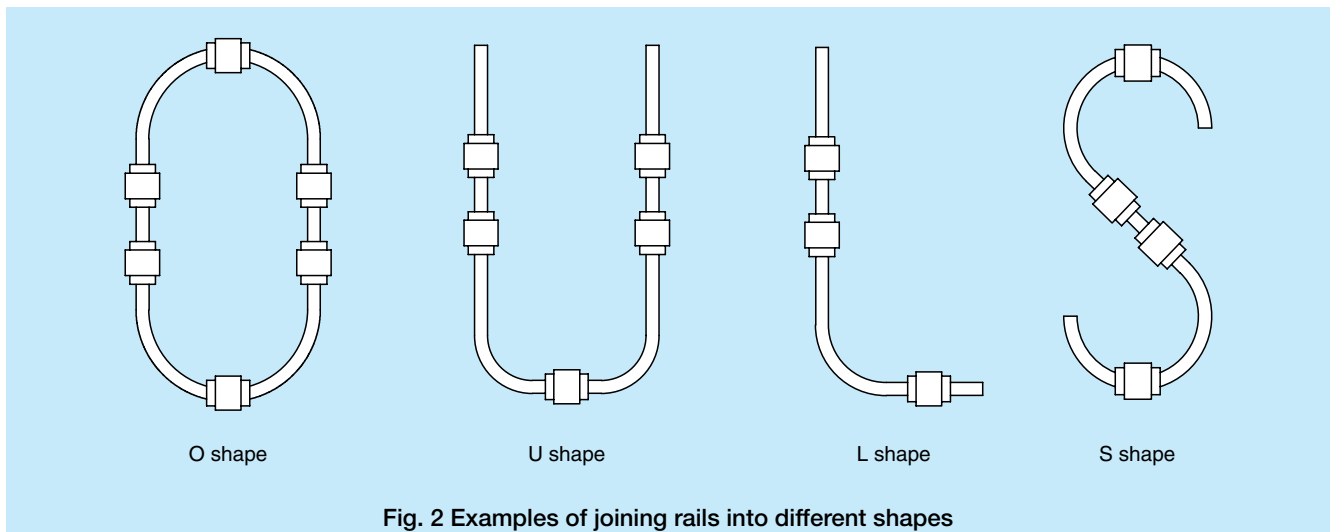

### Shortened transportation time

Unlike the shuttle method, using HMG units in a circulating system allows workpieces to be placed while other workpieces are being inspected or mounted, thus to significantly improve tact time. Increasing the number of tables can further shorten tact time.

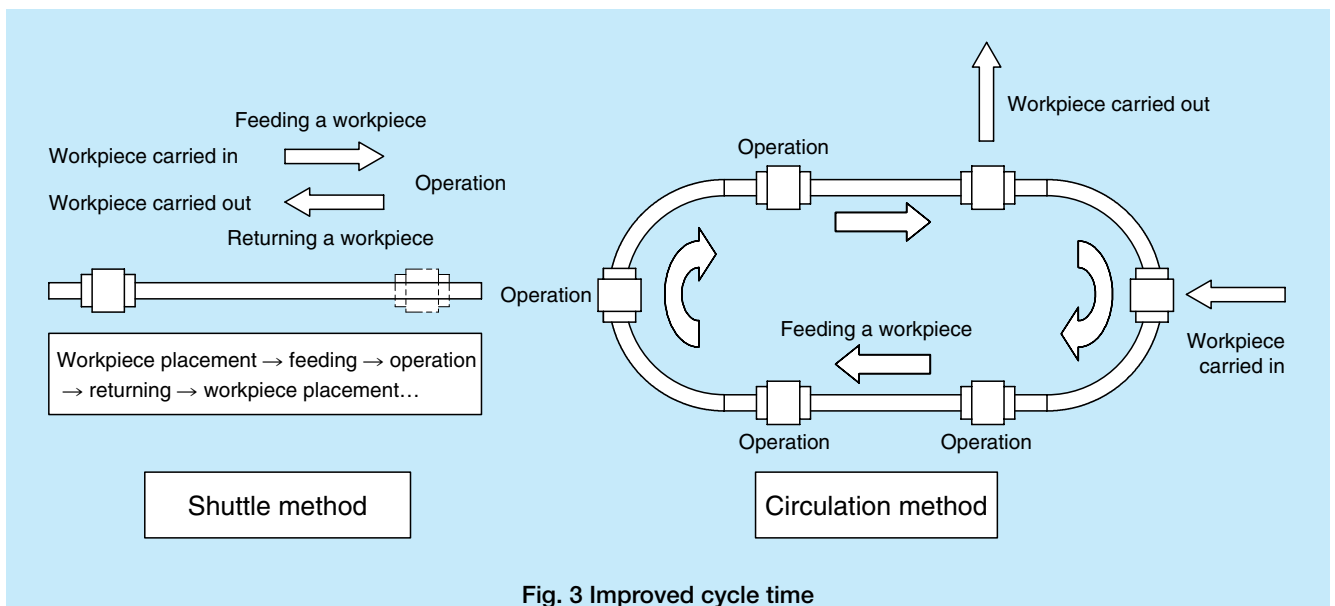

## ● Cost reduction through a simplified mechanism

Combination of straight and curved rails eliminates a lift and a turntable conventionally used for changing directions in the conveyance and production lines. Therefore, use of HMG simplifies the mechanism and eliminates a large number of parts, allowing the cost to be reduced. Additionally, man-hours in designing can also be reduced.

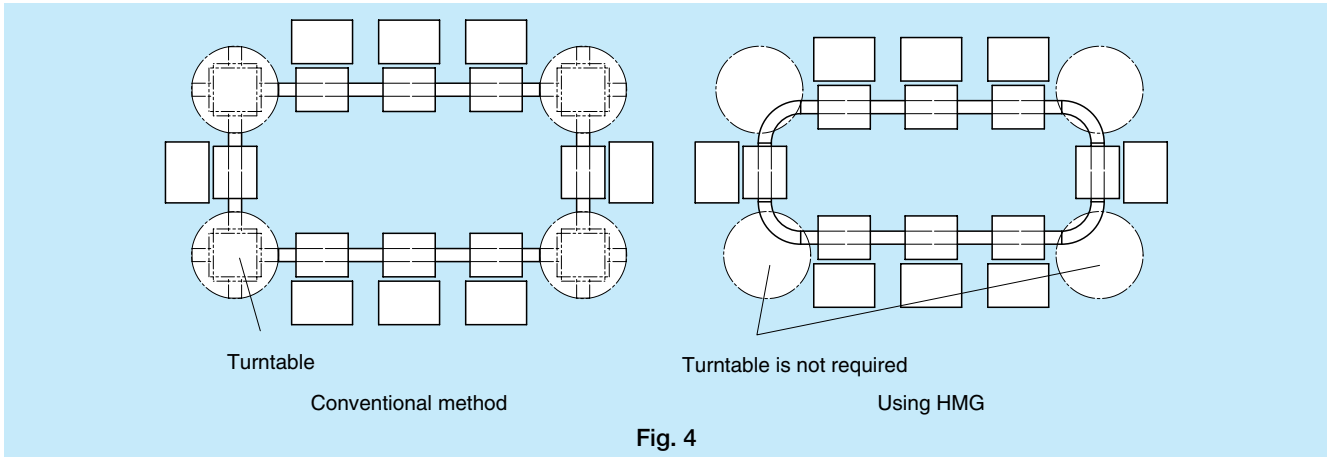

Fig. 4

## ● Load Rating

### ● Load ratings by directions

HMG is capable of receiving all loads applied in the radial, reverse-radial and lateral directions.

Its basic load rating is the load rating in the radial direction as shown in Fig. 5 and the specific value is provided in the corresponding dimension table. The basic load rating is uniform in the 4 directions (radial, reverse-radial and lateral directions). The specific values of each type are provided in Table 1.

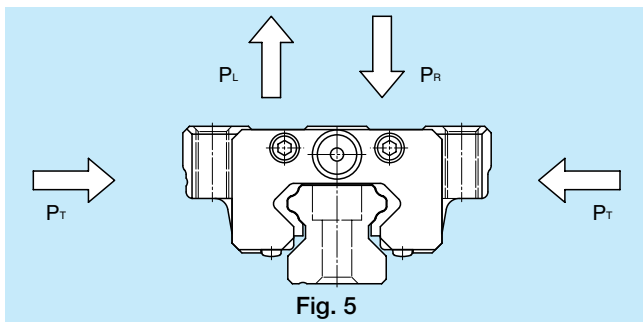

Fig. 5

Table 1 Basic load rating of HMG (kN)

	Dynamic load rating (C)	Static load rating (Co)	
	Resultant load (C)	Straight section (Cost)	Curved section (Cor)
HMG15	2.56	4.23	0.44
HMG25	9.41	10.8	6.7
HMG35	17.7	19.0	11.5
HMG45	28.1	29.7	18.2
HMG65	66.2	66.7	36.2

### Equivalent load

The equivalent load when an LM block of HMG simultaneously receives loads from multiple directions is obtained in the following equation.

$$P_E = P_R(P_L) + P_T$$

$P_E$  : equivalent load (N)

- radial direction
- reverse-radial direction
- lateral direction

$P_R$  : radial load (N)

$P_L$  : reverse-radial load (N)

$P_T$  : lateral load (N)

# Service Life

## Nominal life

The nominal life of HMG is obtained in the following equation.

The dynamic load rating of HMG differs between the straight and the curved sections. When obtaining the nominal life, use the dynamic load rating of the resultant load of the straight and the curved sections.

$$L = \left( \frac{f_T \cdot f_c}{f_w} \cdot \frac{C}{P_c} \right)^3 \times 50$$

- L : nominal life (km)
- C : basic dynamic load rating (N)
- P<sub>c</sub> : calculated value (N)
- f<sub>T</sub> : temperature factor (see the general catalog for details)
- f<sub>c</sub> : contact factor (see the general catalog for details)
- f<sub>w</sub> : load factor (see the general catalog for details)

## Service-life time

When the nominal life has been obtained, the service-life time can be obtained in the following equation if the stroke length and the number of reciprocations remain constant.

$$L_h = \frac{L \times 10^6}{2 \times l_s \times n_1 \times 60}$$

- L<sub>h</sub> : service-life time (h)
- l<sub>s</sub> : stroke length (mm)
- n<sub>1</sub> : number of reciprocations per minute (min<sup>-1</sup>)

## Permissible moment

With HMG, each LM block is capable of receiving moments in all directions. Table 2 shows the permissible moment of an LM block in the M<sub>A</sub>, M<sub>B</sub> and M<sub>C</sub> directions.

Table 2 Static permissible moment of HMG

Unit:kN-m

	M <sub>A</sub>		M <sub>B</sub>		M <sub>C</sub>	
	Straight section	Curved section	Straight section	Curved section	Straight section	Curved section
HMG15	0.008	0.007	0.008	0.010	0.027	0.003
HMG25	0.10	0.04	0.10	0.05	0.11	0.07
HMG35	0.22	0.11	0.22	0.12	0.29	0.17
HMG45	0.48	0.20	0.48	0.22	0.58	0.34
HMG65	1.47	0.66	1.47	0.73	1.83	0.94

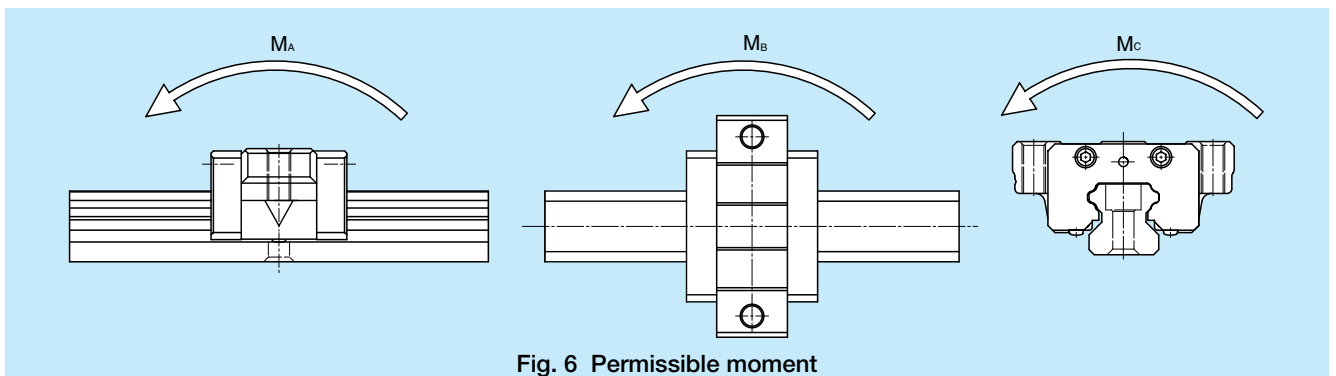

Fig. 6 Permissible moment

# Optional Accessories

If foreign matter or dust enters an LM block, it will lead to abnormal wear, fracture of the raceway and balls and breakage of the ball circulation tunnel, causing the service life to be shortened. THK offers a straight-curved seal and a dedicated C-cap for the LM-rail mounting hole for HMG.

When desiring a straight-curved seal, specify it at time of placing an order for HMG. If the seal is to be mounted after purchasing HMG, THK needs to ask you to return the product.

## 1. Straight-curved seal

For HMG, THK offers a straight-curved seal (Laminated Contact Scraper LaCS) capable of removing foreign matter in both the straight and curved sections.

Mounting this seal on both ends of each LM block can prevent foreign matter or water attached on the LM rail top face or side face from entering the LM block. Since the seal is effective for both the straight section and the curved sections, it can prevent foreign matter from entering an LM block. In addition, it is effective also as a means to prevent a lubricant inside the LM block from leaking.

### Part number of the straight-curved seal

If the straight-curved seal is required, specify it with the symbol indicated in Table 3. Attaching the seal will increase the overall LM block length. For specific dimensions of the seal, refer to the dimension table attached.

Table 3 Symbol of the straight-curved seal

Symbol	Dust-prevention accessory
UU	With an end seal (on both sides)

### Seal resistance

For the maximum seal resistance per LM block for the Straight-Curved Guide HMG with a seal (type UU), refer to the values provided in Table 4.

Table 4 Maximum seal resistance Unit:N

Model No.	Seal resistance
HMG15	3
HMG25	6
HMG35	8
HMG45	12
HMG65	40

These specification values represent values of one block (2 seals).

## 2. Dedicated C-cap for the LM-rail mounting hole

If foreign matter blocks the LM-rail mounting hole of an LM Guide, it may enter the LM block. In such cases, use a dedicated cap so that the top face of the LM rail and the cap are on the same level to prevent foreign matter from entering the block.

Since the dedicated C-cap uses a special synthetic resin with superb oil-resistant and wear-resistant properties, it demonstrates high-resistance performance. To insert the C-cap in the mounting hole, use a flat metal piece as shown in Fig. 7 and gradually hammer it until the cap's top face is on the same level as the top face of the LM rail. When ordering the desiccated C-cap, specify it with the corresponding model number provided in Table 5.

Table 5 Dedicated C-cap

Applicable model No.	C-cap model No.	Bolt to be used	Major dimensions (mm)	
			D	H
HMG15	C4	M4	7.8	1.0
HMG25	C6	M6	11.4	2.7
HMG35	C8	M8	14.4	3.7
HMG45	C12	M12	20.5	4.7
HMG65	C16	M16	26.5	5.7

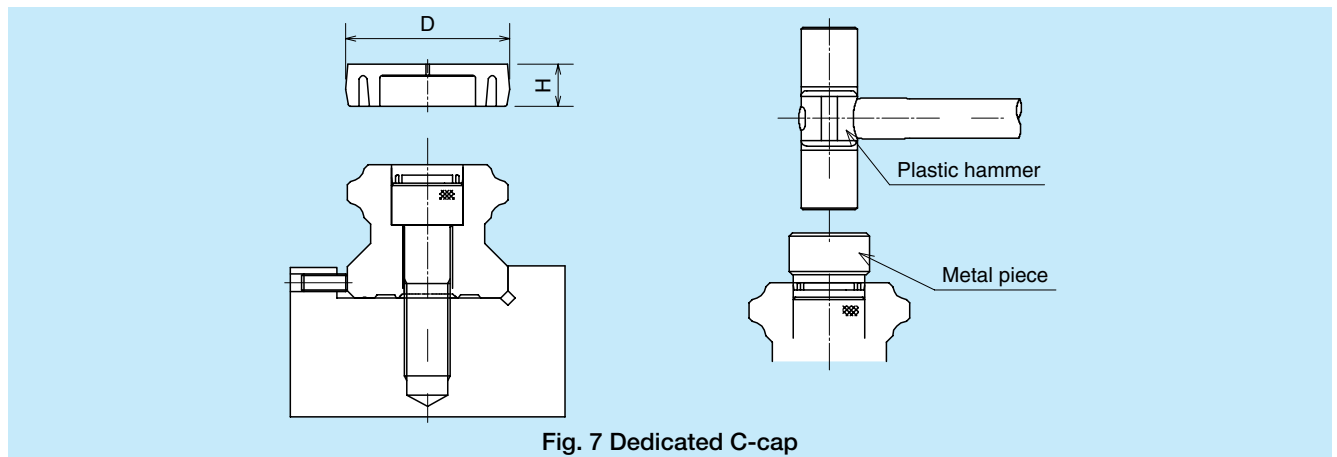

Fig. 7 Dedicated C-cap

# Accuracy Specifications

The accuracy of the Straight-Curved Guide HMG is defined in dimensional tolerance of running parallelism, height and width, and the difference in height and width required when multiple LM blocks are used on a single axis or using multiple axes on the same plane, as shown in Table 6. There will be a clearance in the curved section.

Running parallelism:

See the general catalog for details.

Difference in height M:

See the general catalog for details.

Difference in width  $W_2$ :

See the general catalog for details.

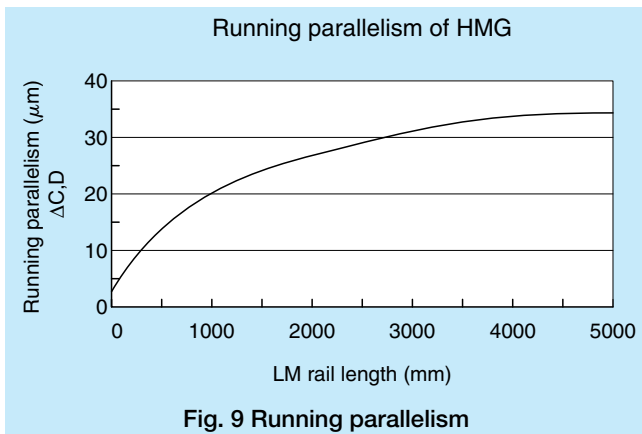
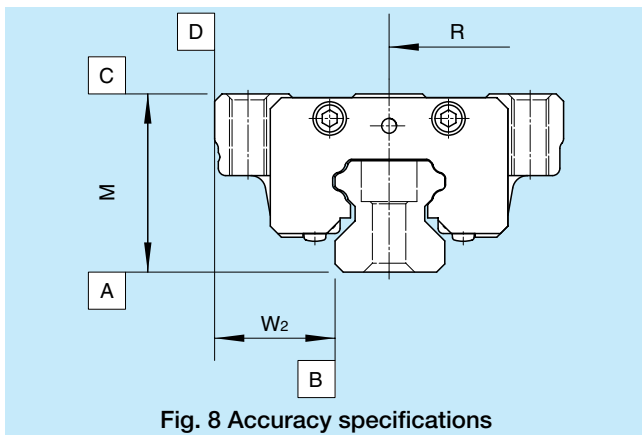

Table 6 Accuracy specifications Unit:mm

Model No.	Accuracy specifications	Normal grade
	Item	No symbol
HMG15	Dimensional tolerance of height M	$\pm 0.1$
	Difference in height M	0.02
	Dimensional tolerance of width $W_2$	$\pm 0.1$
	Difference in width $W_2$	0.02
	Running parallelism of face C against face A	$\Delta C$ (according to Fig. 9)
	Running parallelism of face D against face B	$\Delta D$ (according to Fig. 9)
HMG25 HMG35	Dimensional tolerance of height M	$\pm 0.1$
	Difference in height M	0.02
	Dimensional tolerance of width $W_2$	$\pm 0.1$
	Difference in width $W_2$	0.03
	Running parallelism of face C against face A	$\Delta C$ (according to Fig. 9)
HMG45 HMG65	Running parallelism of face D against face B	$\Delta D$ (according to Fig. 9)
	Dimensional tolerance of height M	$\pm 0.1$
	Difference in height M	0.03
	Dimensional tolerance of width $W_2$	$\pm 0.1$
	Difference in width $W_2$	0.03
	Running parallelism of face C against face A	$\Delta C$ (according to Fig. 9)
HMG65	Running parallelism of face D against face B	$\Delta D$ (according to Fig. 9)



# Radial Clearance

The radial clearance of the Straight-Curved Guide HMG is provided in Table 7.

The radial clearance of the straight-curved guide is applied only to the straight section. Note that there will be a clearance in the curved section.

Table 7 Radial clearance of HMG Unit:  $\mu\text{m}$

	Normal	Light preload
	No symbol	C1
HMG15	-4 ~ +2	-12 ~ -4
HMG25	-6 ~ +3	-16 ~ -6
HMG35	-8 ~ +4	-22 ~ -8
HMG45	-10 ~ +5	-25 ~ -10
HMG65	-14 ~ +7	-32 ~ -14

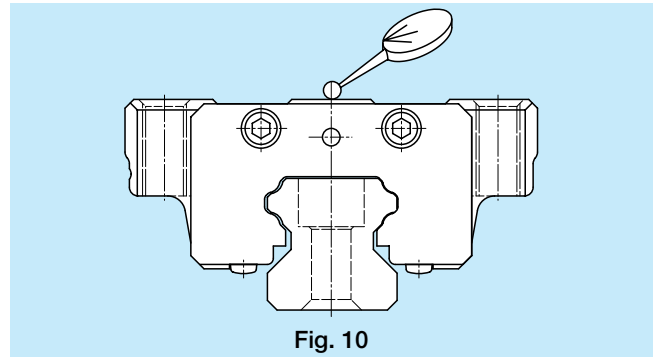

Note: A normal clearance does not take a symbol, while C1 clearance should be expressed in the corresponding model number (refer to the example of model number coding on page 11).

# Precautions on Installation

## Height of the mounting face and the corner radius

In general, a reference piece of metal is required on the side of the LM block and the LM rail's mounting surface in order to ensure easy installation and accurate positioning. For the shoulder height of the reference piece of metal, see Table 8.

The corners of the mounting surface must be machined to have a space or to have a radius equal to or below the radiuses  $r_1$  and  $r_2$  as shown in Table 8 in order not to interfere with the chamfers of the LM block and the LM rail.

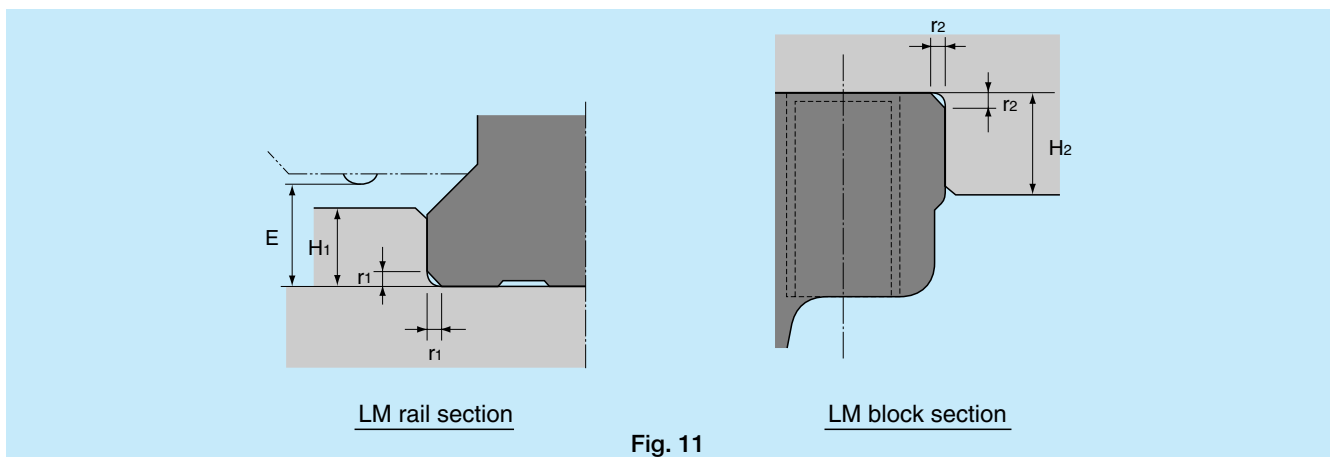

Table 8 The shoulder height and the corner radius of the mounting surface

Unit:mm

Model No.	Corner radius of the LM rail section $r_1$ (max)	Corner radius of the LM block section $r_2$ (max)	Shoulder height of the LM rail section $H_1$	Shoulder height of the LM block section $H_2$	E
HMG15	0.5	0.5	3.0	4.0	3.5
HMG25	1.0	1.0	5.0	5.0	5.5
HMG35	1.0	1.0	6.0	6.0	7.5
HMG45	1.0	1.0	8.0	8.0	10
HMG65	1.5	1.5	10	10	14

## Specifications of unevenness of the joint

Since accuracy tolerance in LM rail installation affects the product's service life, mount LM rails so that the unevenness of each joint is within the specification shown in Table 9. For a joint between curved rails, and joints between curved and connection rails, we recommend using "pushing pieces" as shown in Fig. 12. When joining those rails, place the bumper pieces on the outside, press the "pushing pieces" to the rails, and then adjust the joint to eliminate or minimize the unevenness using adjusting screws from the inside.

Table 9 Specifications for unevenness of the joint Unit:mm

Model No.	Ball raceway, side face	Top face	Max clearance of the joint
HMG15	0.01	0.02	0.6
HMG25	0.01	0.02	0.7
HMG35	0.01	0.02	1.0
HMG45	0.01	0.02	1.3
HMG65	0.01	0.02	1.3

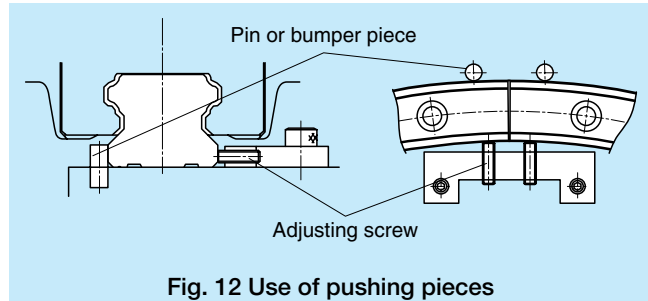

Fig. 12 Use of pushing pieces

Note: Place the pins on the outside and the pushing pieces on the inside.

## Curved sections

With HMG, there is a clearance in each curved section for a structural reason. Therefore, HMG may not be used where highly accurate feeding is required. In addition, the curved section cannot receive a large moment. If a large moment is applied, it is necessary to increase the number of LM blocks or LM rails. For specific values of permissible moments, see Table 2 on page 4.

## Connection LM rails

HMG requires connection rails when LM blocks move from straight to curved sections or when R is inverted such as rails connected in an S shape. Take this into account when designing a system in such applications.

Table 10 Dimensions of connection rails

Unit:mm

Model No.	Dimensions of a connection rail							
	Height	Pitch	Mounting hole	Width		Taper length	Taper depth	Radius
	M <sub>1</sub>	F	d <sub>1</sub> x d <sub>2</sub> x h	W <sub>1</sub>	W <sub>0</sub>	a	b	R
HMG15A	15	60	4.5 x 7.5 x 5.3	15	14.78	28	0.22	150
					14.89		0.11	300
					14.92		0.08	400
HMG25A	22	60	7 x 11 x 9	23	22.83	42	0.17	500
					22.89		0.11	750
					22.92		0.08	1000
HMG35A	29	80	9 x 14 x 12	34	33.77	54	0.23	600
					33.83		0.17	800
					33.86		0.14	1000
					33.90		0.10	1300
HMG45A	38	105	14 x 20 x 17	45	44.71	76	0.29	800
					44.77		0.23	1000
					44.81		0.19	1200
					44.86		0.14	1600
HMG65A	53	150	18 x 26 x 22	63	62.48	107	0.52	1000
					62.66		0.34	1500
					62.74		0.26	2000
					62.80		0.20	2500
					62.83		0.17	3000

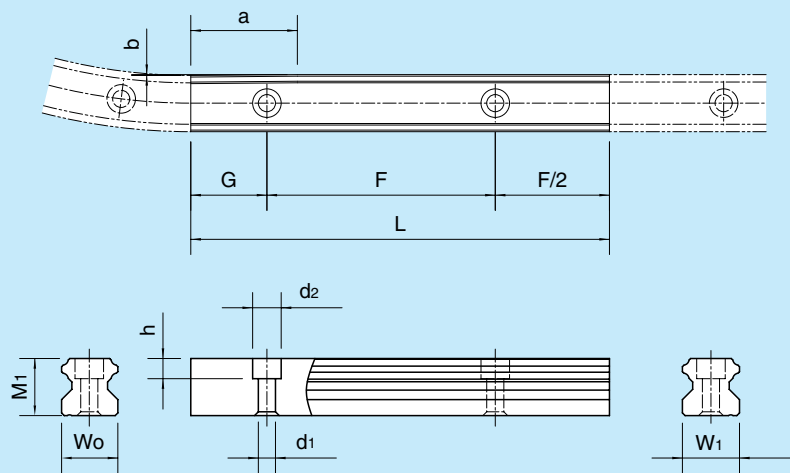

Fig. 13

When 2 axes are used

**Example of model number coding**

**HMG15A 2 UU C1+1000L T+60/150R 6T+60/300R 6T- II**

1
2
3
4
5
6
7
8
9
10
11
12
13

- |  |   |
|--|---|
| <ul style="list-style-type: none"> <li><b>1</b> Model number</li> <li><b>2</b> Number of LM blocks per axis</li> <li><b>3</b> Seal symbol</li> <li><b>4</b> Clearance symbol</li> <li><b>5</b> Overall straight LM rail length per axis</li> <li><b>6</b> Straight LM rail connection symbol</li> <li><b>7</b> Center angle of an inward curved LM rail</li> </ul> | <ul style="list-style-type: none"> <li><b>8</b> Radius of an inward curved LM rail</li> <li><b>9</b> Number of inward curved LM rails connected</li> <li><b>10</b> Center angle of an outward curved LM rail</li> <li><b>11</b> Radius of an outward curved LM rail</li> <li><b>12</b> Number of outward curved LM rails connected</li> <li><b>13</b> Number of axes</li> </ul> |
|--|---|

**Note** - This model number represents single axis units used in one set (if 2 axes are used in parallel, at least 2 sets are required).  
 - HMG does not have a seal as standard.  
 Fig. 14 shows the combination of units according to the above sample of model number coding.

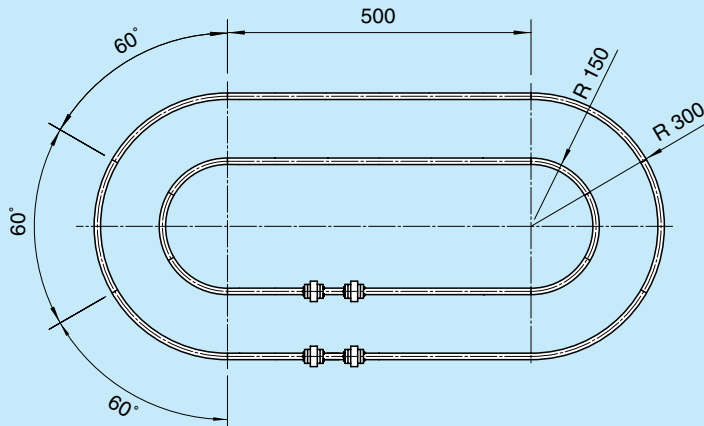

Fig.14 Sample of model number coding

# Examples of Table Mechanisms

The Straight-Curved Guide HMG requires a rotating mechanism or a slide mechanism for the table to rotate the curved sections when 2 or more axes are used or when 2 or more LM blocks are connected on a single axis. Refer to Fig. 15 for examples of such mechanisms.

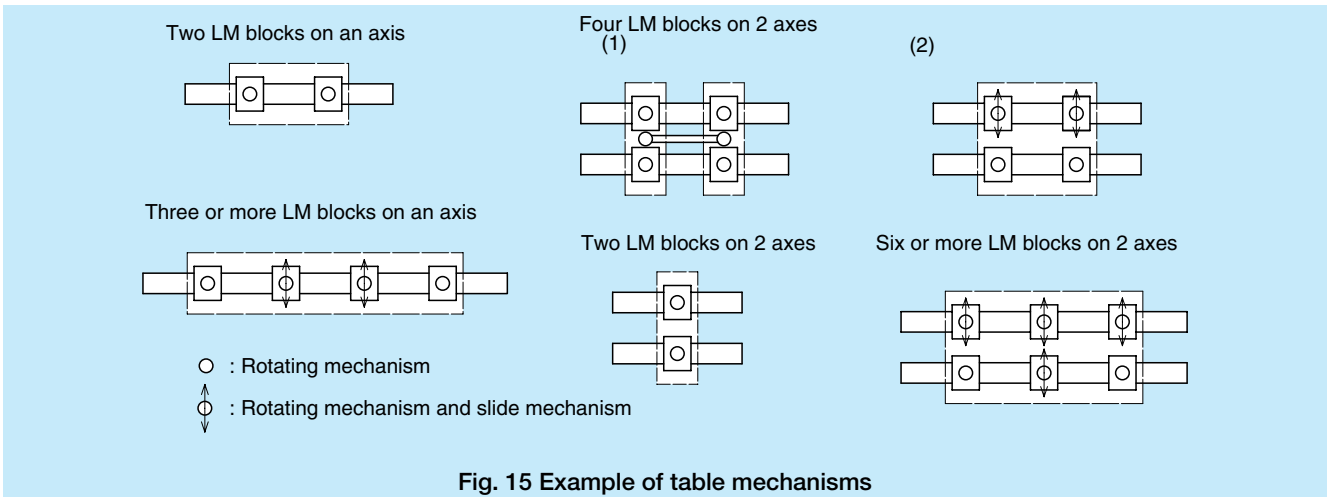
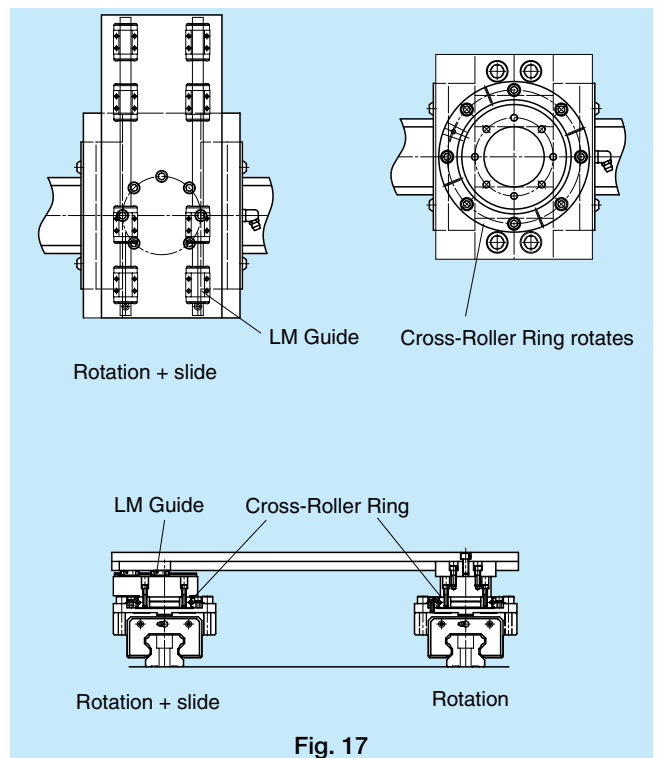
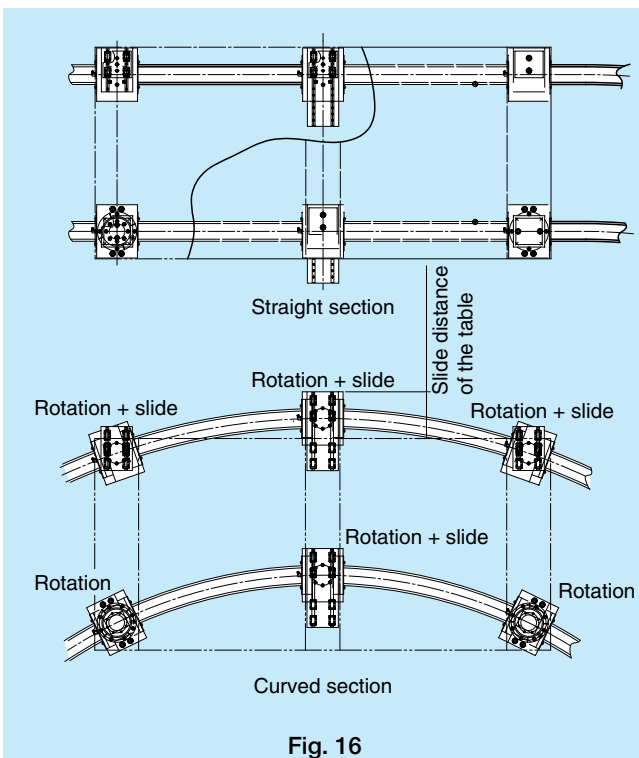
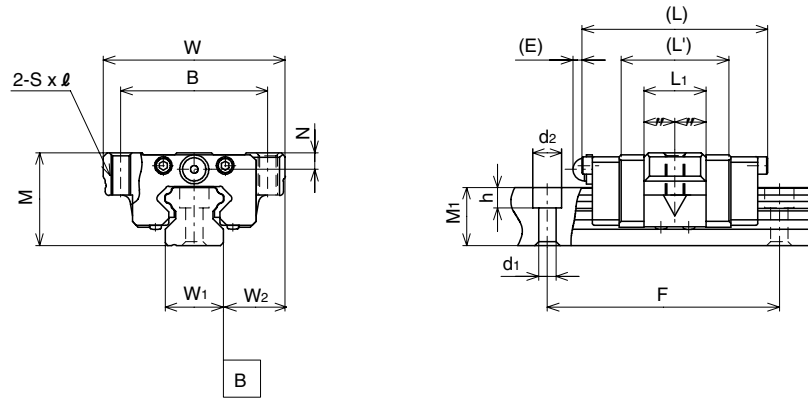

Fig. 16 shows examples of designing a table when units are used on multiple axes. HMG requires a rotating mechanism and a slide mechanism since the table is decentered when an LM block transits from a straight section to a curved section. The amount of eccentric differs according to the radius of the curved section and the LM block span. Therefore, it is necessary to design the system in accordance with the corresponding specifications.

Fig. 17 shows detail drawings of the slide and rotating mechanisms. In Fig. 17, LM Guides are used in the slide mechanism and Cross-Roller Rings in the rotating mechanism to achieve smooth sliding and rotating motions. For driving the Straight-Curved Guide, belt drives and chain drives are available.



# Table of Dimensions of HMG



Model No.	Outer dimensions					Dimensions of LM block				Dimensions of LM rail			
	M	W	L	L'	B	S x l	L <sub>1</sub>	N	E	Straight rail			Height
										W <sub>1</sub>	W <sub>2</sub>	F	M <sub>1</sub>
HMG15A	24	47	48	28.8	38	M5 x 11	16	4.3	5.5	15	16	60	15
HMG25A	36	70	62.2	42.2	57	M8 x 16	25.6	6	12	23	23.5	60	22
HMG35A	48	100	80.6	54.6	82	M10 x 21	32.6	8	12	34	33	80	29
HMG45A	60	120	107.6	76.6	100	M12 x 25	42.6	10	16	45	37.5	105	38
HMG65A	90	170	144.4	107.4	142	M16 x 37	63.4	19	16	63	53.5	150	53

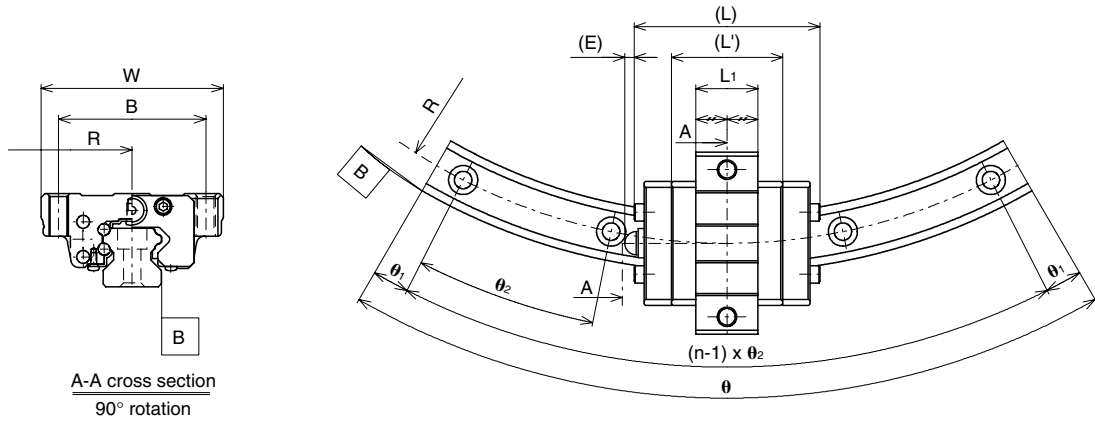

Mounting hole	Dimensions of LM rail						Basic dynamic load rating (C) Resultant load (C) kN	Basic static load rating (Co)	
	d <sub>1</sub> x d <sub>2</sub> x h	R	n	θ°	θ <sub>1</sub> °	θ <sub>2</sub> °		Straight section (Cost) kN	Curved section (Cor) kN
4.5 x 7.5 x 5.3	150	3	60	7	23	2.56	4.23	0.44	
	300	5	60	6	12				
	400	7	60	3	9				
7 x 11 x 9	500	9	60	2	7	9.41	10.8	6.7	
	750	12	60	2.5	5				
	1000	15	60	2	4				
9 x 14 x 12	600	7	60	3	9	17.7	19.0	11.5	
	800	11	60	2.5	5.5				
	1000	12	60	2.5	5				
	1300	17	60	2	3.5				
14 x 20 x 17	800	8	60	2	8	28.1	29.7	18.2	
	1000	10	60	3	6				
	1200	12	60	2.5	5				
	1600	15	60	2	4				
18 x 26 x 22	1000	8	60	2	8	66.2	66.7	36.2	
	1500	10	60	3	6				
	2000	12	45	0.5	4				
	2500	13	45	1.5	3.5				
	3000	10	30	1.5	3				

# THK Straight-Curved Guide HMG

## Precautions on use

### ●Precautions on handing the product

Dropping or hitting an LM block may fracture it.

Tilting an LM block or LM rail may cause it to fall by its own weight. With HMG 45, if an LM block comes off from the LM rail, balls will fall. Take much care in handling the product.

### ●Service temperature/humidity

Since the LM block uses a special resin, do not use it at temperature at -20°C or below or at 80°C or above. Also, use it in an environment with humidity at 80% or less where no condensation occurs.

### ●Service environment

Ordinary greases may not be used in a place where there are constant vibrations, in a clean room, in vacuum, or in a special environment with low temperature or high temperature. Contact THK for advice.

### ●Lubrication

Lubrication intervals vary depending on the service conditions. Contact THK for details.

●“LM Guide,” “Caged Ball,” “” and “QZ” are registered trademarks of THK CO., LTD.

●The photo in this catalog may not accurately represent the actual product.

●Appearance and specifications are subject to change without notice. Contact THK before placing an order.

●Although great care has been taken in the production of this catalog, THK will not take any responsibility for damage resulting from typographical errors or omissions.

●For the export of our products or technologies and for the sale for exports, THK in principle complies with the foreign exchange law and the Foreign Exchange and Foreign Trade Control Law as well as other relevant laws.

For export of THK products as single items, contact THK in advance.

All rights reserved

## THK THK CO., LTD.

HEAD OFFICE 3-11-6, NISHI-GOTANDA, SHINAGAWA-KU, TOKYO 141-8503 JAPAN  
INTERNATIONAL SALES DEPARTMENT PHONE:(03)5434-0351 FAX:(03)5434-0353

### U. S. A.

#### CHICAGO

PHONE:(847)310-1111 FAX:(847)310-1182

#### NEW JERSEY

PHONE:(201)529-1950 FAX:(201)529-1962

#### LOS ANGELES

PHONE:(714)891-6752 FAX:(714)894-9315

#### SAN FRANCISCO

PHONE:(925)455-8948 FAX:(925)455-8965

#### ATLANTA

PHONE:(770)840-7990 FAX:(770)840-7897

#### DETROIT

PHONE:(248)858-9330 FAX:(248)858-9455

#### BOSTON

PHONE:(781)575-1151 FAX:(781)575-9295

#### INDIANAPOLIS

PHONE:(317)243-3496 FAX:(317)243-3499

#### MINNEAPOLIS

PHONE:(612)953-4442 FAX:(612)953-4441

#### CANADA (MISSISSAUGA,ONT)

PHONE:(905)712-2922 FAX:(905)712-2925

#### BRASIL (SÃO PAULO)

PHONE:(011)3924-0911 FAX:(011)3924-0900

### GERMANY

#### DÜSSELDORF

PHONE:(02102)74250 FAX:(02102)7425299

#### STUTTGART

PHONE:(07150)91990 FAX:(07150)9199888

#### MÜNCHEN

PHONE:(089)3706160 FAX:(089)37061626

#### U.K. (MILTON KEYNES)

PHONE:(01908)222159 FAX:(01908)222161

#### FRANCE (LYON)

PHONE:(0437)49.14.00 FAX:(0437)49.14.01

#### ITALY (MILAN)

PHONE:(039)2842079 FAX:(039)2842527

#### SWEDEN (STOCKHOLM)

PHONE:(08)4457630 FAX:(08)4457639

#### AUSTRIA (LINZ)

PHONE:(07229)51400 FAX:(07229)51400-79

#### SPAIN (BARCELONA)

PHONE:(093)652-5740 FAX:(093)652-5746

#### PGM BALLSCREWS LIMITED (COVENTRY)

PHONE:(02476)841900 FAX:(02476)611032

#### PGM BALLSCREWS IRELAND LIMITED (DUBLIN)

PHONE:(01)4628101 FAX:(01)4629080

### TAIWAN

#### TAIPEI

PHONE:(02)2585-8554 FAX:(02)2585-8495

#### TAICHUNG

PHONE:(04)2359-1505 FAX:(04)2359-1506

#### SOUTERN

PHONE:(07)698-3437 FAX:(07)698-3483

#### CHINA

#### BEIJING

PHONE:(10)6590-3557 FAX:(10)6590-3557

#### HONG KONG

PHONE:2376-1091, 2376-1252 FAX:2376-0749

#### MALAYSIA (KUALA LUMPUR)

PHONE:(03)9287-1137 FAX:(03)9287-8071

#### INDIA (BANGALORE)

PHONE:(080)330-1524 FAX:(080)330-1524

#### KOREA (SEOUL)

PHONE:(02)3463-0351 FAX:(02)3017-0351

