

R-Guide Type HCR

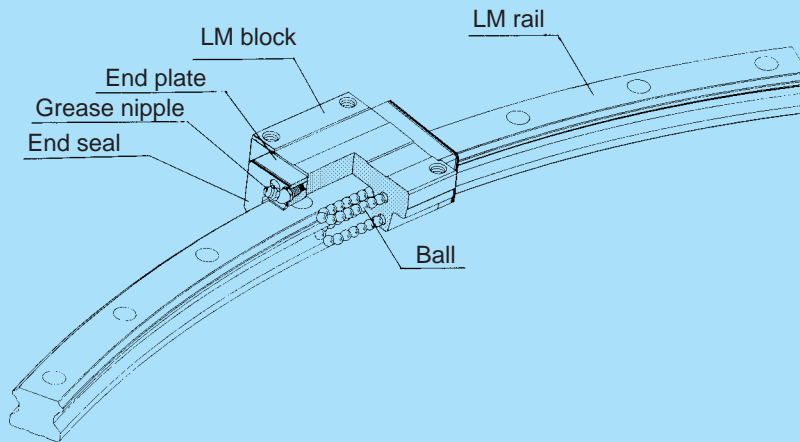

Fig. 1 Construction of R-Guide Type HCR

Construction and Features

Balls roll in four rows of precision-ground raceways on an LM rail and an LM block. The end plate attached to the LM block causes the trains of balls to circulate.

The R-Guide represents the culmination of THK's technological know-how. It is the first circular-shaped guide of its kind in the world.

An innovative development based on the four-way equal-load LM Guide, R-Guide type HSR, which has already established a proven record in actual applications, forms a totally new line-up.

Permits freedom of design

Unlike rotary and cross-roller bearings, the R-Guide allows the same number of modes of motion as do LM blocks.

Simply place LM blocks at the loading points to achieve the most efficient structural design.

Short assembly time

The R-Guide enables high-precision motion with no clearance, which is impossible in circular motion performed using a slide guide or a cam follower. Assembly involves only bolting LM blocks to LM rails. It's that simple.

Circular but inexpensive

The greater the diameter, the more cost-effective it gets. Circular motion of 5m or greater, which is impossible with swiveling bearings, can easily be achieved using type HCR, making it easy to assemble, dismantle, and reassemble large equipment.

Simple construction

Type HCR construction is basically the same as that of the LM Guide. The low-profile design achieved by minimizing the height of the R-Guide allows it to bear loads in all directions.

Load Rating and Permissible Moment in Various Directions

Load rating

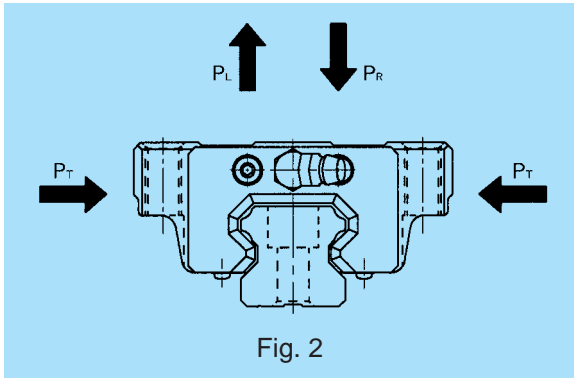

Type HCR can bear loads in all four directions: radial, reverse-radial, and the two lateral directions.

The basic load ratings in all four directions (radial, reverse-radial, and the two lateral directions) are equivalent to one another. The values are given in the corresponding dimension tables.

Equivalent load

The equivalent load for type HCR when loads in various directions are exerted on its LM block simultaneously can be obtained using the following equation:

$$P_E = P_R (P_L) + P_T$$

where

- P_E : equivalent load (N)
 - In the radial direction
 - In the reverse-radial direction
 - In the lateral direction

P_R : radial load (N)

P_L : reverse-radial load (N)

P_T : lateral load (N)

Permissible moment

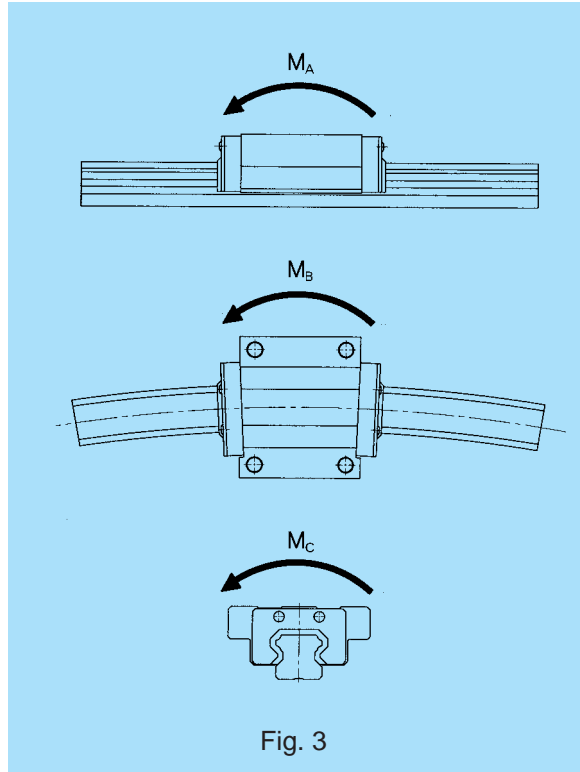

In type HCR, a single LM block can bear moments in all directions. Table 1 gives the permissible moments in directions M_A , M_B , and M_C for a single LM block.

Table 1 Type HCR
Static Permissible Moment

Unit: kNm

Model No.	M_A	M_B	M_C
HCR 12	0.03	0.03	0.05
HCR 15	0.07	0.07	0.10
HCR 25	0.27	0.27	0.4
HCR 35	0.64	0.64	1.0
HCR 45	1.3	1.3	2.1
HCR 65	4.2	4.2	6.6

Accuracy Standards

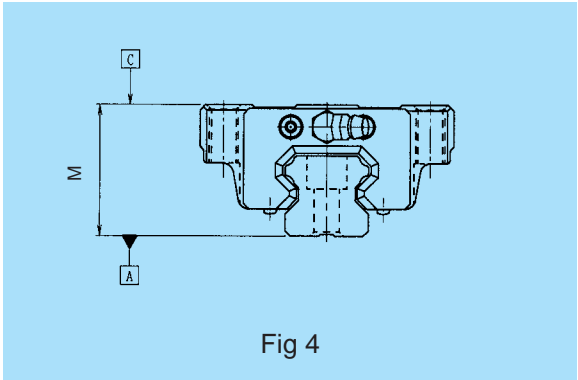

Fig 4

The accuracy of type HCR is shown in Table 2 for each model number, classified into the normal and high grades.

Table 2 Type HCR Accuracy Standard

Unit : mm

Model No.	Accuracy standard	Normal	High
	Item	No symbol	H
HCR 12 HCR 15 HCR 25 HCR 35	Tolerance for height M	±0.2	±0.2
	Tolerance for the height M difference among LM blocks	0.05	0.03
	Running Parallelism of LM block surface C with surface A	C (as per Fig. 5)	
HCR 45 HCR 65	Tolerance for height M	±0.2	±0.2
	Tolerance for the height M difference among LM blocks	0.06	0.04
	Running Parallelism of LM block surface C with surface A	C (as per Fig. 5)	

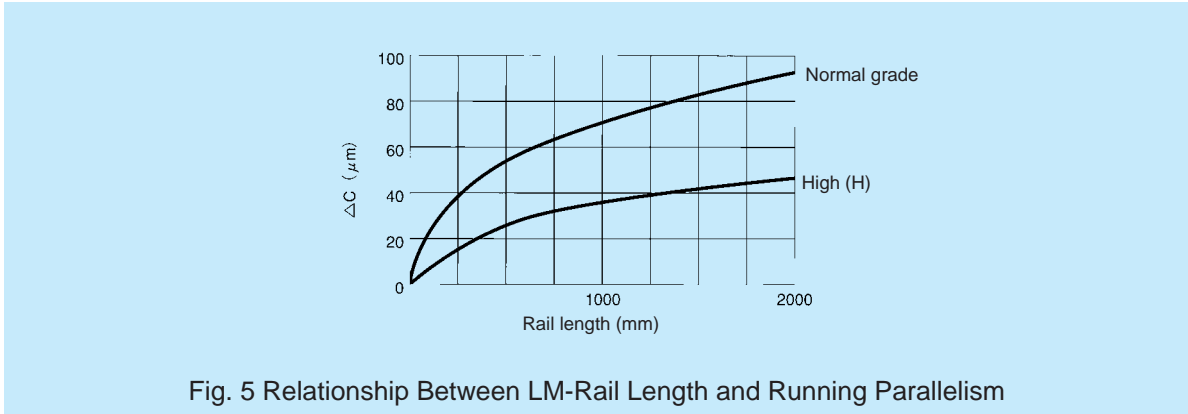

Fig. 5 Relationship Between LM-Rail Length and Running Parallelism

Radial clearance

Table 3 presents the radial clearances of types HCR.

Table 3 Type HCR Radial Clearances

Unit: μm

Model No.	Clearance symbol	Nomal	Under a light preload
	No symbol		C1
HCR 12		-3 ~ +3	-6 ~ -2
HCR 15		-4 ~ +2	-12 ~ -4
HCR 25		-6 ~ +3	-16 ~ -6
HCR 35		-8 ~ +4	-22 ~ -8
HCR 45		-10 ~ +5	-25 ~ -10
HCR 65		-14 ~ +7	-32 ~ -14

Model-number coding

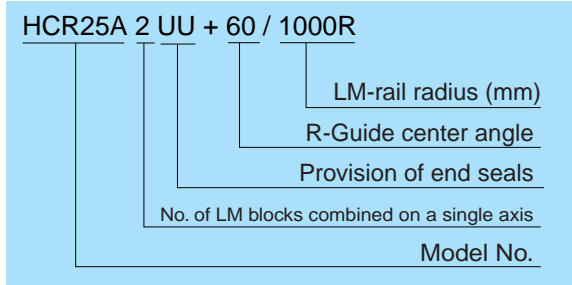

Note: One model number in this style is required for one LM Guide in a one-axis configuration. (In a two-axis configuration in which two LM Guides are used in parallel, the R-Guide center angles and the LM-rail radii differ from one another. Therefore, two model numbers are required.)

Contamination Protection

From our wide array of products for type HCR, you can select the one best suited for your situation. (For details on seals, see “Contamination Protection” for type HSR on page A-249.)

If your choice is applicable to your system, please note that in some models, attaching a contamination-protection accessory to an LM block changes the block’s overall length. Add the increment specified in the corresponding dimension table to dimension L.

Not all LM Guide models accept all contamination-protection accessories. Please check Table 4.

Table 4 Type HCR: LM Block Overall Length with a Contamination-protection Accessory Attached

Unit : mm

Model. No.	No symbol		UU		SS		DD		ZZ		KK		LL		RR	
HCR12A+60/100R	O	41.6	O	44.6	x	-	x	-	x	-	x	-	x	-	x	-
HCR15A+60/150R	O	54.6	O	56.5	O	56.5	Δ	61.8	Δ	57.8	Δ	63	O	56.5	O	56.5
HCR15A+60R/300R HCR15A+60R/400R	O	51.6	O	53.5	O	53.5	Δ	58.8	Δ	54.8	Δ	60	O	53.5	O	53.5
HCR25A+60/500R HCR25A+60/750R HCR25A+60/1000R	O	76.1	O	79	O	79	Δ	86.7	Δ	81.5	Δ	89.1	O	79	O	79
HCR35A+60/600R HCR35A+60/800R HCR35A+60/1000R HCR35A+60/1300R	O	102.4	O	105.4	O	105.4	Δ	113	Δ	107.8	Δ	115.4	O	105.4	O	105.4
HCR45A+60/800R HCR45A+60/1000R HCR45A+60/1200R HCR45A+60/1600R	O	132	O	139	O	139	Δ	146.2	Δ	144.2	Δ	151.4	O	139	O	139
HCR65A+60/1000R HCR65A+60/1500R HCR65A+45/2000R HCR65A+45/2500R HCR65A+30/3000R	O	191	O	198	O	198	Δ	205.2	Δ	203.2	Δ	210.4	O	198	O	198

Note: O = Applicable

x = Not applicable

Δ = Whether the seal is applicable or not depends on the rail radius

Seal resistance

With regard to end seals for type HCR...UU, Table 5 Precautions on Use

Table 5 Maximum Resistance Value of seals to Type HCR

Unit: N

Model No.	Seal resistance value
HCR 12	1.2
HCR 15	2.0
HCR 25	3.9
HCR 35	11.8
HCR 45	19.6
HCR 65	34.3

Precautions on Use

In type HCR, be careful not to allow the balls to drop off when removing the LM block from the LM rail.

Mounting-Surface Height and Corner Profile

Normally, mounting surfaces for LM blocks and rails have lateral reference surfaces to aid in positioning rails and blocks with a high degree of accuracy.

For the reference-surface shoulder height, see Table 6.

Furthermore, provide enough space to the corner profile of a mounting surface so that the corner does not interfere with chamfers made on the LM blocks or rails, or provide the corner with a radius smaller than corner radius r specified in Table 6.

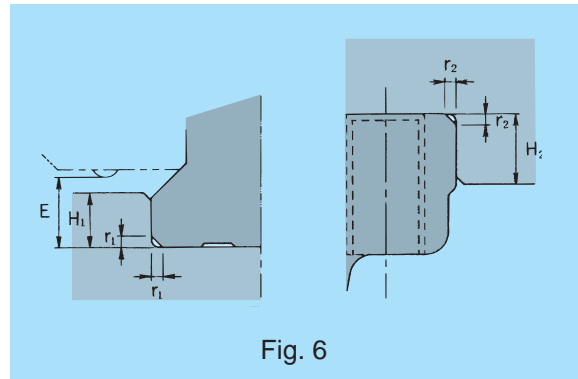

Fig. 6

Table 6 Mounting-Surface Shoulder Height and Corner Radius

Unit: mm

Model No.	LM rail fillet radius r_1 (Max.)	LM block fillet radius r_2 (Max.)	LM rail shoulder height H_1	LM block shoulder maximum height H_2	E
HCR 12	0.8	0.5	2.6	6	3.1
HCR 15	0.5	0.5	3	4	3.5
HCR 25	1.0	1.0	5	5	5.5
HCR 35	1.0	1.0	6	6	7.5
HCR 45	1.0	1.0	8	8	10
HCR 65	1.5	1.5	10	10	14

LM-Rail Mounting Procedures

To mount the LM rails of the R-Guide, install reference cleats pins can be used on the rail reference section (inner) in advance, and hold the rails against them. Fasten the rails in place, pressing them against the cleats while holding the blocks or the like from the side opposite the reference section.

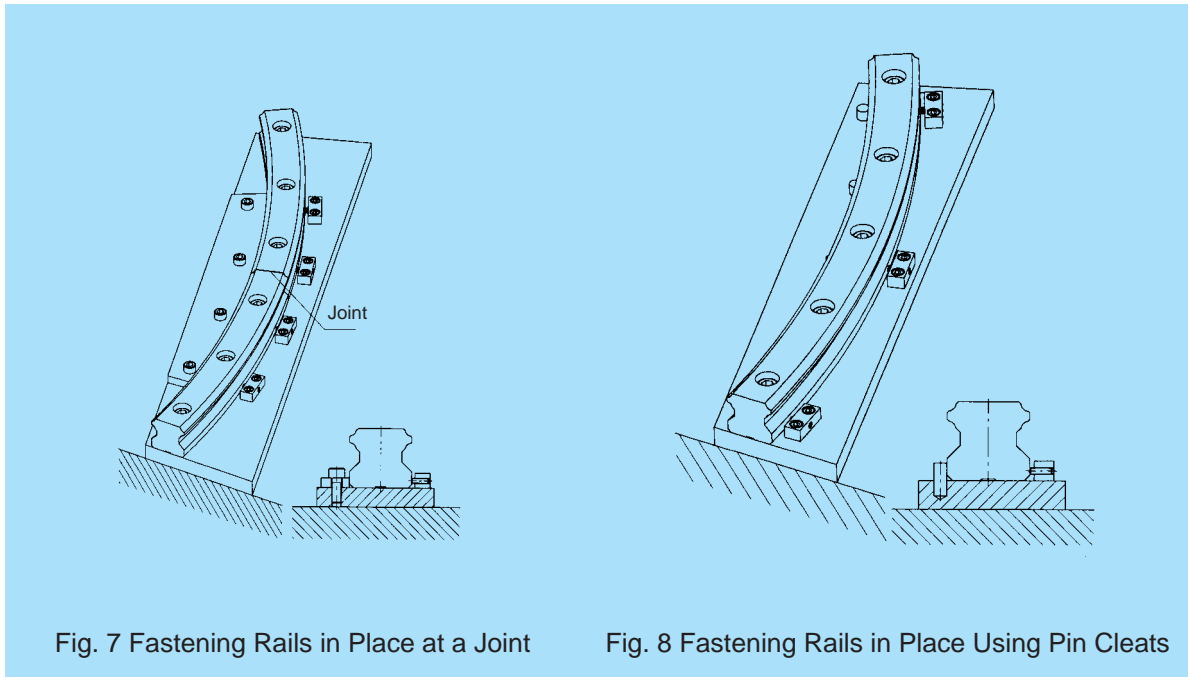
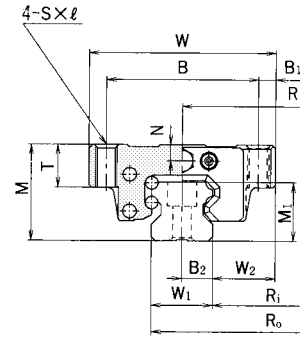

Fig. 7 Fastening Rails in Place at a Joint

Fig. 8 Fastening Rails in Place Using Pin Cleats

R-Guide type HCR



A-A Cross section

Model No.	LM block dimensions												R	Ro
	Width			Length		Height					Grease nipple			
	W	B	B ₁	L	C	M	S × l	T	L ₁	N	E			
HCR 12 A+60/ 100 R	39	32	3.5	44.6	18	18	M4 × 5	5	30.5	3.4	3.5	PB1021B	100	106
HCR 15 A+60/ 150 R	47	38	4.5	56.5	24	24	M5 × 10	11	38.8	4.5	5.5	PB1021B	150	157.5
HCR 15 A+60/ 300 R				53.5	28		M5 × 11						300	307.5
HCR 15 A+60/ 400 R				400	407.5									
HCR 25 A+60/ 500 R	70	57	6.5	79	45	36	M8 × 16	16	59.5	6	12	B-M6F	500	511.5
HCR 25 A+60/ 750 R													750	761.5
HCR 25 A+60/1000 R													1000	1011.5
HCR 35 A+60/ 600 R	100	82	9	105.4	58	48	M10 × 21	21	80.4	8	12	B-M6F	600	617
HCR 35 A+60/ 800 R													800	817
HCR 35 A+60/1000 R													1000	1017
HCR 35 A+60/1300 R													1300	1317
HCR 45 A+60/ 800 R	120	100	10	139	70	60	M12 × 25	25	98	10	16	B-PT1/8	800	822.5
HCR 45 A+60/1000 R													1000	1022.5
HCR 45 A+60/1200 R													1200	1222.5
HCR 45 A+60/1600 R													1600	1622.5
HCR 65 A+60/1000 R	170	142	14	198	106	90	M16 × 37	37	147	19	16	B-PT1/8	1000	1031.5
HCR 65 A+60/1500 R													1500	1531.5
HCR 65 A+45/2000 R													2000	2031.5
HCR 65 A+45/2500 R													2500	2531.5
HCR 65 A+30/3000 R													3000	3031.5

Notes:

- We can provide rails with radii other than those given in this table. If you require these, contact us.
- The R-Guide center angles given in this table represent the maximum that we can produce. R-Guides with a greater angle are designed for connected use. If you require these, contact us.
- We can provide R-Guides with side seals. If you require these, contact us.

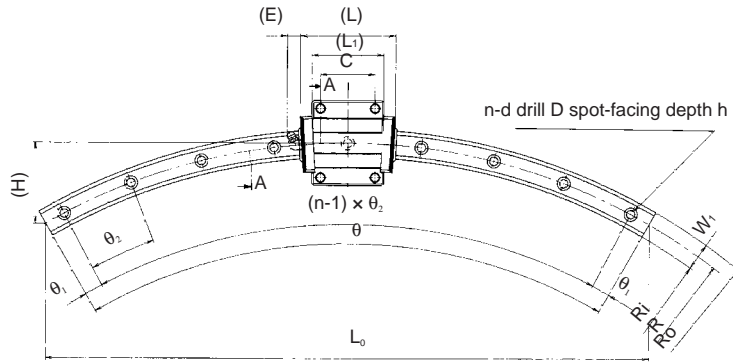

Unit : mm

LM-rail dimensions												Basic load rating	
Ri	Lo	H	Width		Height		d x D x h	n	θ	θ ₁	θ ₂	C	C ₀
			W ₁	W ₂	B ₂	M ₁						kN	kN
94	100	13.4	12	13.5	6	11	3.5 × 6 × 5	3	60°	7°	23°	4.7	8.53
142.5	150	20.1	15	16	7.5	15	4.5 × 7.5 × 5.3	3	60°	7°	23°	6.66	10.8
292.5	300	40						5	60°	6°	12°	8.33	13.5
392.5	400	54	23	23.5	11.5	22	7 × 11 × 9	7	60°	3°	9°	19.9	34.4
488.5	500	67						9	60°	2°	7°		
738.5	750	100						12	60°	2.5°	5°		
988.5	1000	134	34	33	17	29	9 × 14 × 12	15	60°	2°	4°	37.3	61.1
583	600	80						7	60°	3°	9°		
783	800	107						11	60°	2.5°	5.5°		
983	1000	134						12	60°	2.5°	5°		
1283	1300	174	45	37.5	22.5	38	14 × 20 × 17	17	60°	2°	3.5°	60	95.6
777.5	800	107						8	60°	2°	8°		
977.5	1000	134						10	60°	3°	6°		
1177.5	1200	161						12	60°	2.5°	5°		
1577.5	1600	214	63	53.5	31.5	53	18 × 26 × 22	15	60°	2°	4°	141	215
968.5	1000	134						8	60°	2°	8°		
1468.5	1500	201						10	60°	3°	6°		
1968.5	1531	152						12	45°	0.5°	4°		
2468.5	1913	190						13	45°	1.5°	3.5°		
2968.5	1553	102	10	30°	1.5°	3°							

• For permissible moments M_A , M_B , and M_C , see page A-377.